

12.5a 6.3a 3.2a

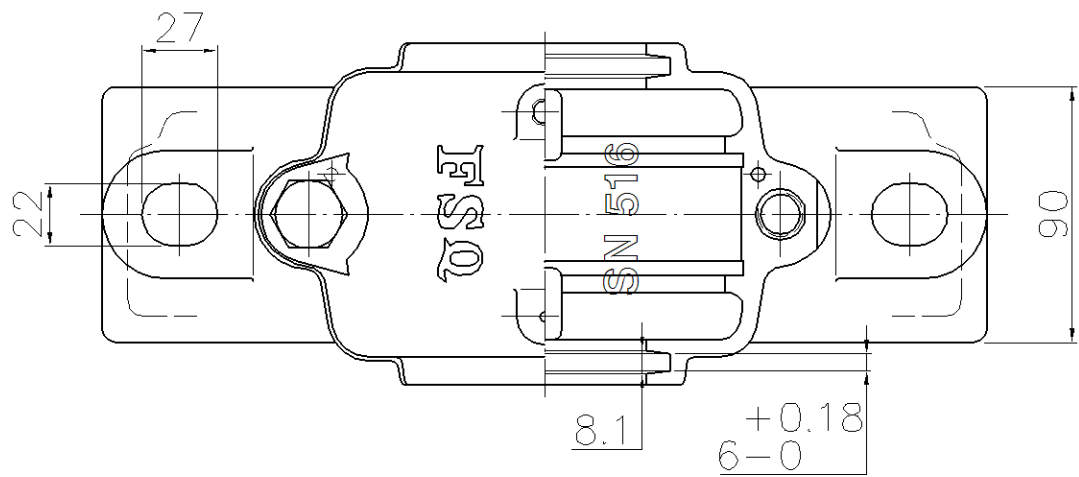

ITEM	DESCRIPTION	DETAIL	MATERIAL	Q'TY
1	CAP CASTING	SN516	FC200	1
2	BASE CASTING	SN516	FC200	1
3	HEX.HEAD BOLT	M16x2.0Px80LG	AISI-1010	2
4	LOCK WASHER	M16	AISI-1045	2
5	DOWEL PIN	φ5x12LG	AISI-1045	2
6	GREASE NIPPLE	PT 1/8	AISI-1010	1
7	METAL PLUG	PT 1/8	AISI-1010	1

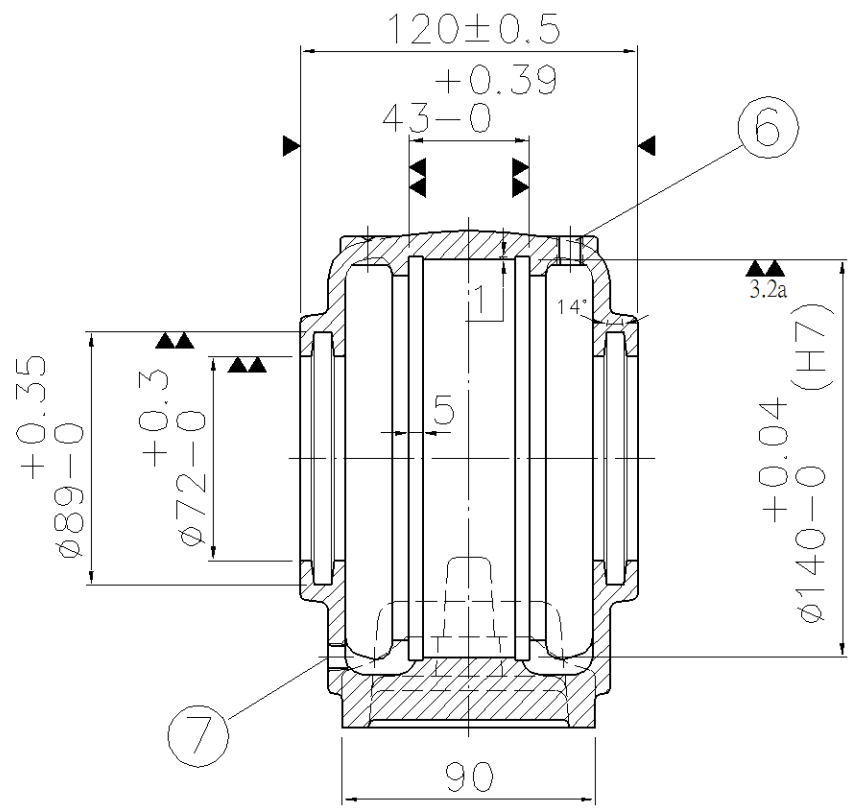
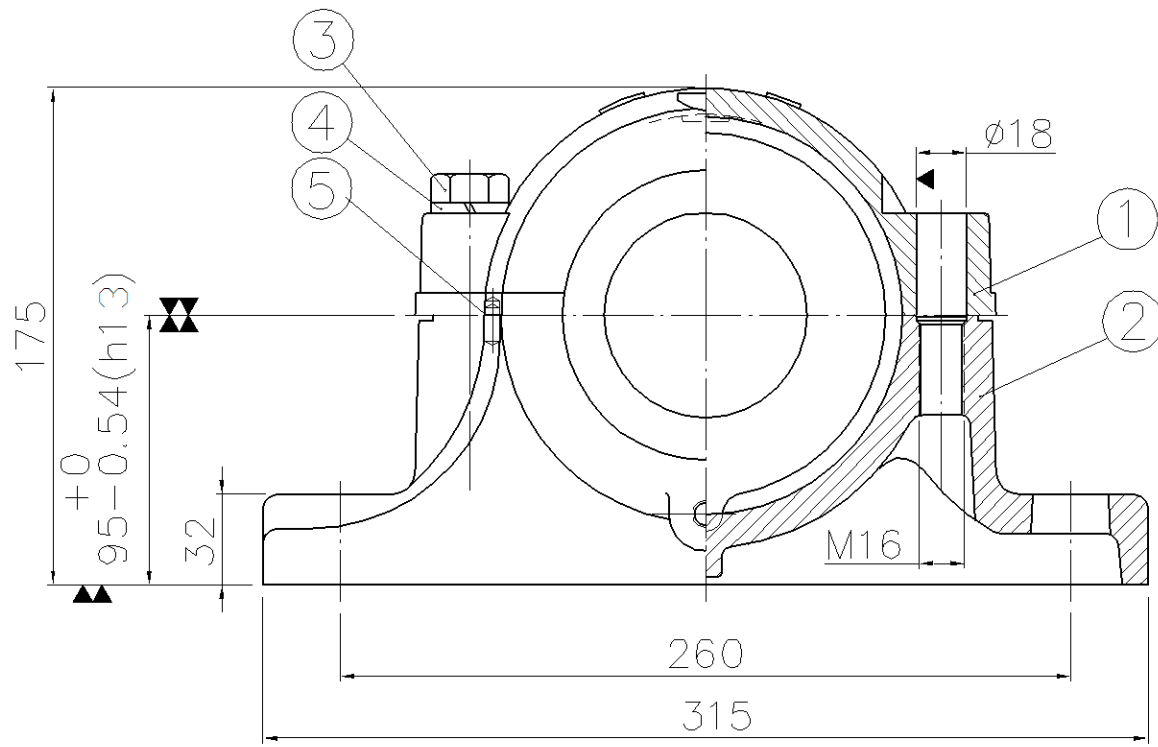

FAIR FRIEND ENT. GROUP.

REV.	MARK	CAREER	NAME	DATE

敬告 RESTRICTED
 此圖乃友迦工業(股)公司財產,未經本公司正式授權,不得私自影印或將內容透漏與第三者。
 THIS DRAWING IS PROPERTY OF FAIRSKQ (TAIWAN) CO., LTD. AND IS TRANSMITTED TO YOU AS A CONFIDENTIAL DISCLOSURE. IT SHALL NOT BE COPIED OR IT'S CONTENTS REVEALED TO OUTSIDE PARTIES WITHOUT WRITTEN CONSENT OF FAIRSKQ (TAIWAN) CO., LTD.

NAME	DATE	FAIRSKQ (TAIWAN) CO., LTD.		
DRAWN C.M.T	2010/01/21	DRAWING NAME	DRAWING NO	EDITION
CHECKED K.Y.S	2010/01/21	SN516	PB11516D	00
SCALE	Issue			
CAD NO MANUAL CHANGES				